



MORELUX POLE TECHNOLOGY
(MALAYSIA)



PRODUCT CATALOG 2026/2027

ABOUT US



Founded in 2009, we are an international manufacturer specializing in high-quality aluminium and steel poles and masts. Headquartered in Ningbo, China, our operations are supported by a large-scale 45,000 sqm manufacturing facility in China and 1,200 sqm manufacturing plant in Malaysia, enabling efficient production and reliable global supply. With strong in-house capabilities covering design, manufacturing, and supply, we have grown into one of the leading exporters of poles and masts worldwide, delivering engineered solutions across infrastructure, lighting, and industrial applications.

OUR MARKET

Our products are trusted across key global markets, with a strong presence spanning North America, Africa, the Middle East, South & Southeast Asia, East Asia, and Oceania, reflecting our capability to deliver reliable solutions worldwide.

15+
Years of
Experience

150+
Exporting
Countries

45000+
Production
Area (m²)

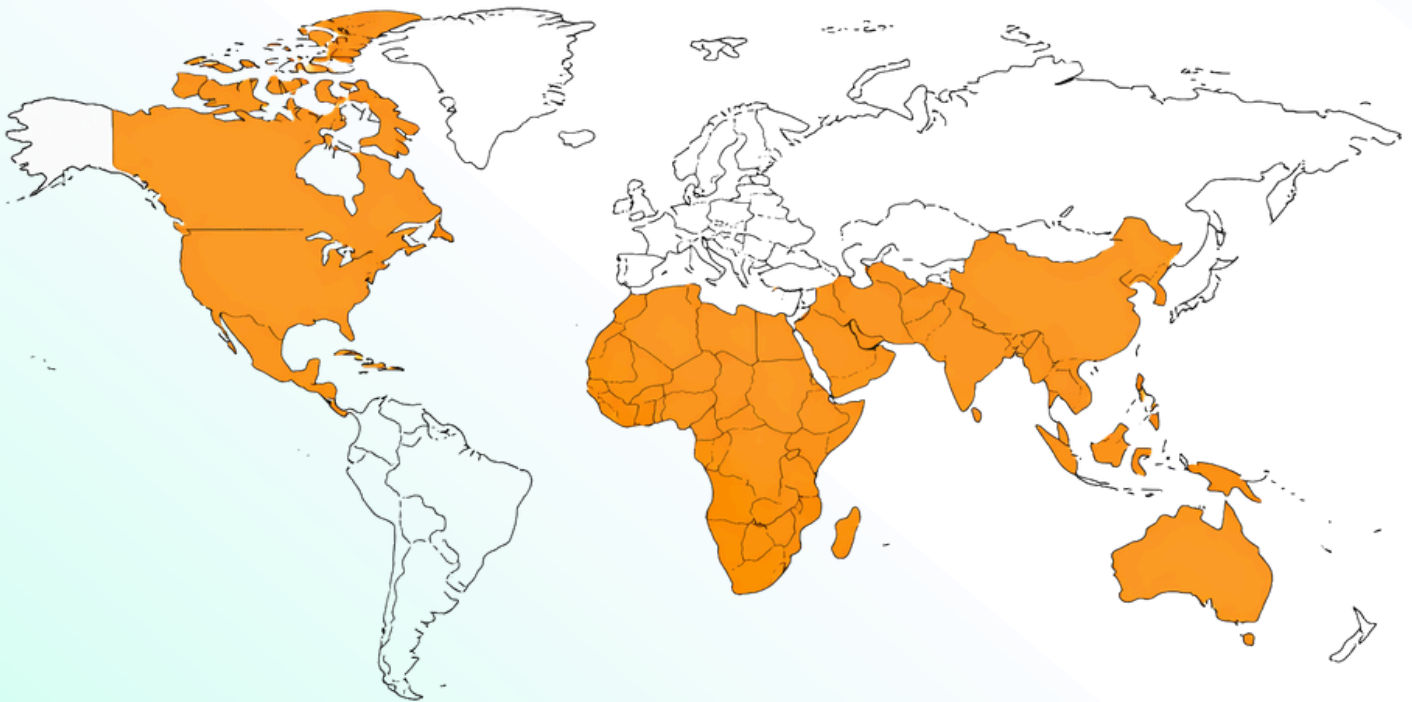

OUR FACILITIES



Our factory are equipped with advanced automated and precision machinery, enabling efficient production of both steel and aluminium poles. This integrated setup ensures high accuracy, consistent quality, and scalable output, supporting custom designs and large-volume manufacturing for global markets.

 Location: Malaysia Manufacturing Plant



Laser Cutting Machine
(6000W)



12M Press Brake Machine
(1400T)



12M Pole Shut Welding Machine



Robotic Welding Machine



Straightening Machine



CNC Machine

 Location: China Manufacturing Plant

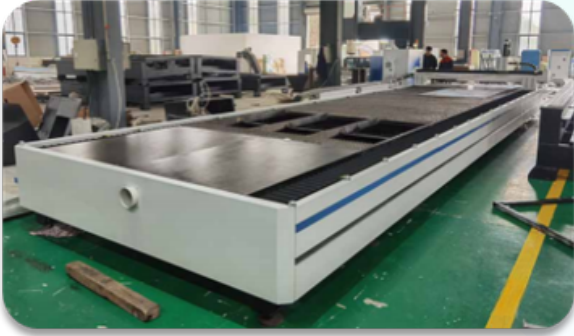

Laser Cutting Machine
(4000W)



14M Press Machine
(1600T)



Automatic Welding Machine



Robotic Welding Machine

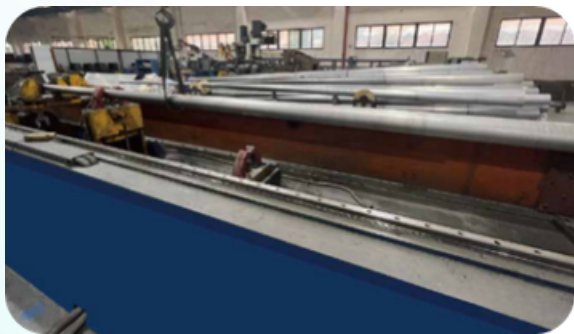

13.5M Aluminium Spinner Machine



T6 Heat Treatment Oven



13.5M Automatic Anodized Pool



Automatic Painting Line

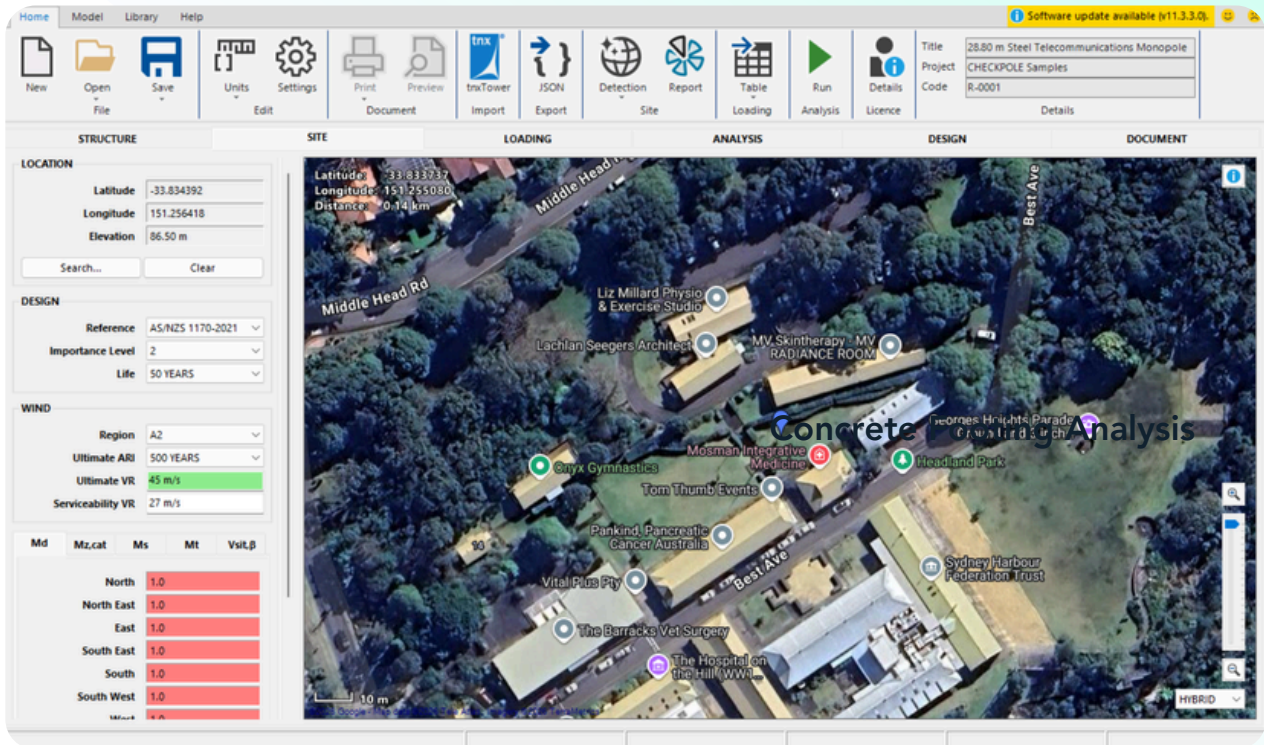

Site Specific Simulation



Type of Calculation

QUALITY ASSURANCE POLICY



Morelux is committed to delivering lighting poles and structural columns that meet or exceed customer expectations, statutory requirements, and applicable international standards. Quality is embedded throughout our design, manufacturing, and delivery processes.

All products are engineered and manufactured in accordance with recognized standards such as AASHTO, BS EN, AS/NZS, MS, and other relevant specifications. Structural designs are verified using advanced engineering software and reviewed by qualified personnel to ensure safety, reliability, and performance.

We maintain strict control over materials, fabrication, welding, galvanizing, and finishing, with inspections and testing conducted at key production stages to ensure conformity and long-term durability.

Our Quality Management System emphasizes continual improvement through audits, corrective actions, and employee training. Management is fully committed to providing the resources and leadership necessary to uphold quality, customer satisfaction, and sustainable infrastructure solutions.

TABLE OF CONTENT

About Us	Page I
Our Market	Page II
Our Facilities	Page III
Our Expertise	Page V
Quality Assurance Policy	Page VII
Lighting Column	
Solar Lighting Pole	Page 03
Street Lighting Pole	Page 05
Floodlighting Pole	Page 09
Mid-hinged Pole	Page 11
Climbing Rung Pole	Page 13
Multi-segment Tubular Pole	Page 15
High Mast	Page 17
Stadium Mast	Page 19
Special Application Column	
CCTV Pole	Page 23
Traffic Light Pole	Page 25
Telecommunication Monopole	Page 27
Multi-function Smart Pole	Page 29
Aesthetic Column	
Decorative Lighting Pole	Page 33
Compound Lighting Pole	Page 35
Landscape Lighting Pole	Page 36





LIGHTING COLUMN



SOLAR LIGHTING POLE

Our solar lighting poles provide an energy-efficient and sustainable lighting solution, combining durable pole design with integrated solar technology. Engineered for reliable performance and low maintenance, they deliver consistent illumination while supporting green and off-grid applications in urban and remote environments.

Technical Specification:

- Lighting poles are designed to comply with major international standards, including AASHTO, AS/NZS, BS EN, MS, and SANS, ensuring safety and global acceptance.
- Structural design and analysis are performed using certified pole design software to verify strength and stability.
- All steel materials are manufactured in accordance with BS EN 10025 or approved equivalent standards.
- Welding works are carried out in compliance with BS EN 1011-2 to ensure structural quality.
- Finished products are hot-dip galvanized to ISO 1461 for corrosion protection and long service life.



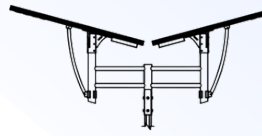
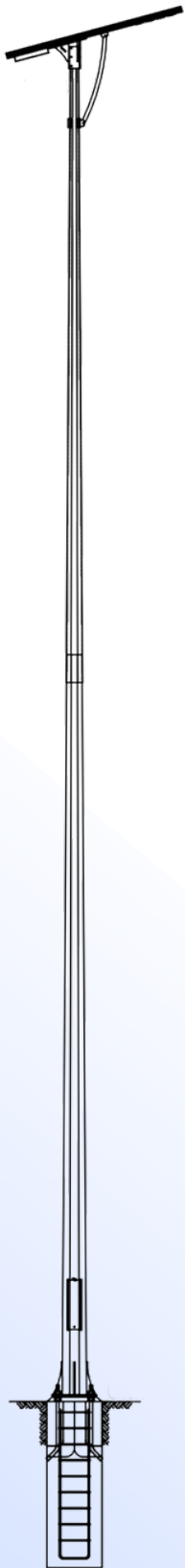

Design A

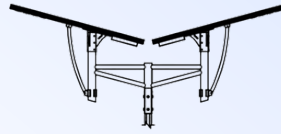

Design B

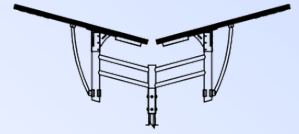

Design C

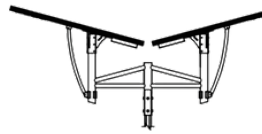

Design D

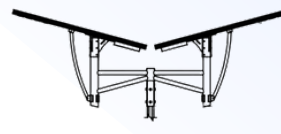

Design E

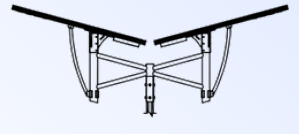

Design F

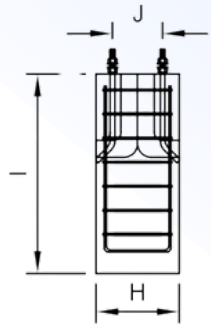
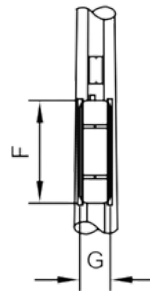
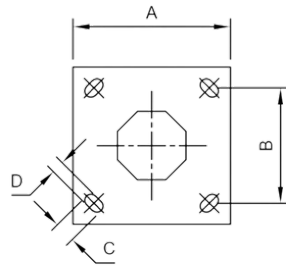

Flange Mounted:

Pole (M)	Top & Bottom AF			Base Flange Plate			
	Light Duty	Medium Duty	Heavy Duty	Width (A)	C-C (B)	Hole (C x D)	Thickness
6	60 / 135	-	-	300	220	40 x 24	12
8	60 / 158	81 / 173	-	300	220	40 x 24	12
9	60 / 161	81 / 181	94 / 215	300	220	40 x 24	15
10	60 / 173	81 / 197	94 / 230	350	260	50 x 28	16
12	60 / 197	81 / 218	94 / 260	400	300	50 x 28	18
Pole (M)	Service Door		J-Bolt		Concrete Footing		
	Height (E)	Size (F x G)	Diameter	Length	Width (H)	Height (I)	C-C (J)
6	305	450 x 100	20	450	350	900	220
8	305	450 x 110	20	450	400	1000	220
9	610	450 x 110	20	450	400	1000/1300	220
10	610	450 x 110	24	570	450	1100/1300	260
12	610	450 x 120	24	570	500	1200/1500	300

STREET LIGHTING POLE



Our street lighting poles are engineered for durability, safety, and modern urban aesthetics. Built with high-quality materials and precision manufacturing, they deliver reliable performance in all weather conditions while supporting a wide range of lighting and smart-city applications. Designed to enhance visibility and streetscape appeal, they are a dependable solution for roads, townships, and public spaces.

Technical Specification:

- Lighting poles are designed to comply with major international standards, including AASHTO, AS/NZS, BS EN, MS, and SANS, ensuring safety and global acceptance.
- Structural design and analysis are performed using certified pole design software to verify strength and stability.
- All steel materials are manufactured in accordance with BS EN 10025 or approved equivalent standards.
- Welding works are carried out in compliance with BS EN 1011-2 to ensure structural quality.
- Finished products are hot-dip galvanized to ISO 1461 for corrosion protection and long service life.



Octagonal



16-Sided

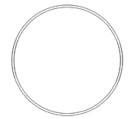

Round



TYPE OF DOOR OPENING

Designed with a discreet door opening, the street lighting pole offers safe, easy access to internal components, simplifying maintenance without compromising appearance or durability. Below are the type of door openings available.



Steel Door



Fiber Door

Double Slotted Hinge Service Door



Side Hinged Service Door



Sliding Service Door
(Up)

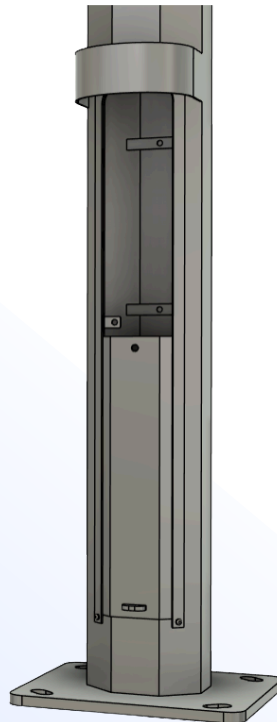

Sliding Service Door
(Down)

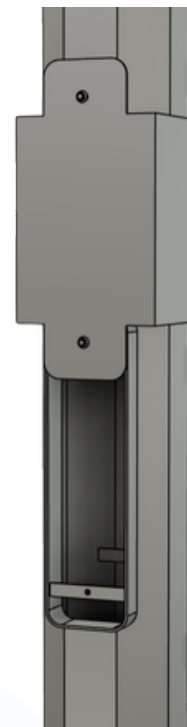

Anti Thief Door

CURVED ARM

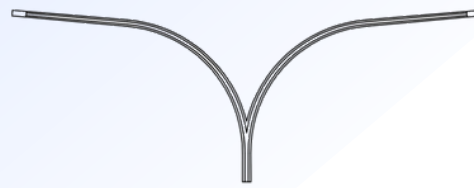
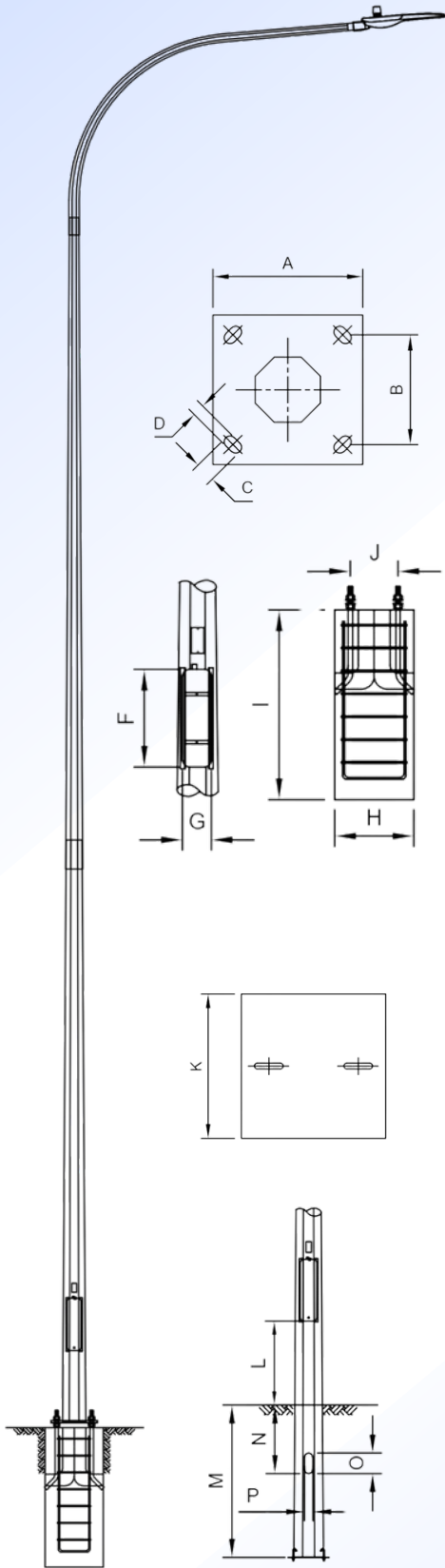

Double Arm



Single Arm

Flange Mounted:

Pole (M)	Section Height			Base Flange Plate			
	Bottom	Int	Top	Width (A)	C-C (B)	Hole (C x D)	Thickness
4	4000	-	-	250	195	35 x 20	9
6	6000	-	-	300	220	40 x 24	12
8	6450	-	1800	300	220	40 x 24	12
9	2000	5600	1800	300	220	40 x 24	15
10	3000	5600	1800	350	260	50 x 28	16
12	5000	5600	1800	400	300	50 x 28	18

Pole (M)	Service Door		J-Bolt		Concrete Footing		
	Height (E)	Size (F x G)	Diameter	Length	Width (H)	Height (I)	C-C (J)
4	305	305 x 90	16	280	300	600	195
6	305	450 x 100	20	450	350	900	220
8	305	450 x 110	20	450	400	1000	220
9	610	450 x 110	20	450	400	1000	220
10	610	450 x 110	24	570	450	1100	260
12	610	450 x 120	24	570	500	1200	300

Planted Type:

Pole (M)	Section Height			Anti-Sink Plate	
	Bottom	Int	Top	Width (K)	Thickness
4	5000	-	-	250	4
6	7200	-	-	250	4
8	2485	5600	1800	300	4
9	3400	5600	1800	300	4
10	4500	5600	1800	300	4
12	6700	5600	1800	300	4

Pole (M)	Service Door		Planting Depth		
	Height (L)	Size (F x G)	Depth (M)	Cable Depth (N)	Cable Entry (O x P)
4	305	305 x 90	1000	500	150 x 50
6	305	450 x 100	1200	500	150 x 60
8	305	450 x 110	1300	500	150 x 60
9	610	450 x 110	1400	500	150 x 60
10	610	450 x 110	1500	500	150 x 60
12	610	450 x 120	1700	500	150 x 60

SHORT ARM

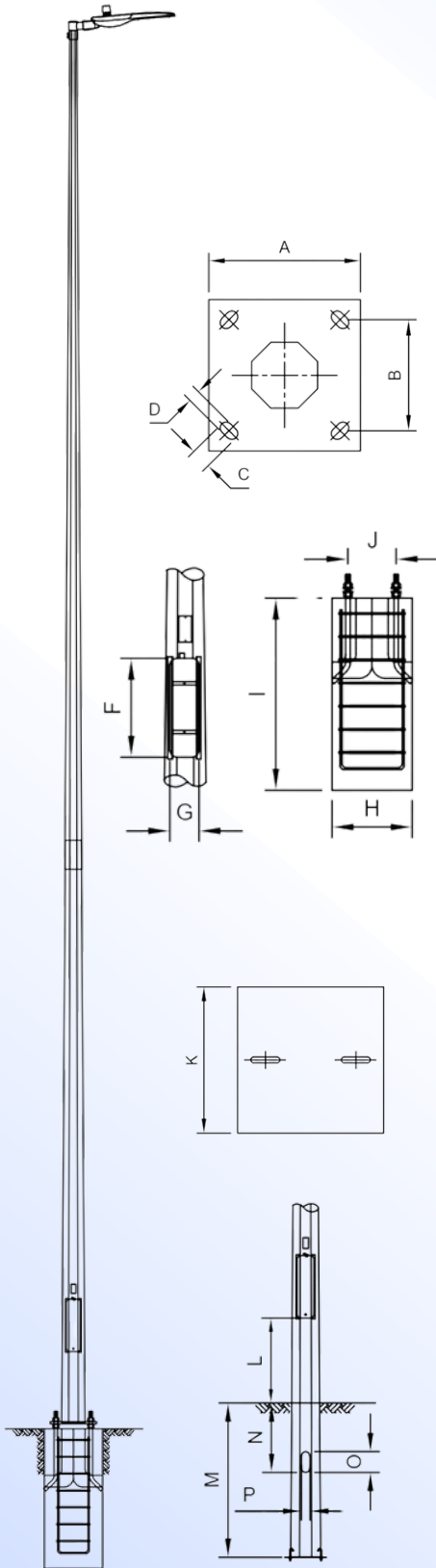

Double Short Arm



Single Short Arm

Flange Mounted:

Pole (M)	Section Height			Base Flange Plate			
	Bottom	Int	Top	Width (A)	C-C (B)	Hole (C x D)	Thickness
4	4000	-	-	250	195	35 x 20	9
6	6000	-	-	300	220	40 x 24	12
8	6450	-	1800	300	220	40 x 24	12
9	2000	-	7200	300	220	40 x 24	15
10	3000	-	7200	350	260	50 x 28	16
12	5000	-	7200	400	300	50 x 28	18

Pole (M)	Service Door		J-Bolt		Concrete Footing		
	Height (E)	Size (F x G)	Diameter	Length	Width (H)	Height (I)	C-C (J)
4	305	305 x 90	16	280	300	600	195
6	305	450 x 100	20	450	350	900	220
8	305	450 x 110	20	450	400	1000	220
9	610	450 x 110	20	450	400	1000	220
10	610	450 x 110	24	570	450	1100	260
12	610	450 x 120	24	570	500	1200	300

Planted Type:

Pole (M)	Section Height			Anti-Sink Plate	
	Bottom	Int	Top	Width (K)	Thickness
4	5000	-	-	250	4
6	7200	-	-	250	4
8	2485	-	7200	300	4
9	3400	-	7200	300	4
10	4500	-	7200	300	4
12	6700	-	7200	300	4

Pole (M)	Service Door		Planting Depth		
	Height (L)	Size (F x G)	Depth (M)	Cable Depth (N)	Cable Entry (O x P)
4	305	305 x 90	1000	500	150 x 50
6	305	450 x 100	1200	500	150 x 60
8	305	450 x 110	1300	500	150 x 60
9	610	450 x 110	1400	500	150 x 60
10	610	450 x 110	1500	500	150 x 60
12	610	450 x 120	1700	500	150 x 60



FLOOD LIGHTING POLE

Our flood lighting poles are designed to deliver powerful, uniform illumination for large areas with strength and reliability. Engineered for high wind resistance and heavy-load support, they provide stable performance for ports, stadiums, industrial sites, and public spaces while maintaining a clean, robust design.

Technical Specification:

- Lighting poles are designed to comply with major international standards, including AASHTO, AS/NZS, BS EN, MS, and SANS, ensuring safety and global acceptance.
- Structural design and analysis are performed using certified pole design software to verify strength and stability.
- All steel materials are manufactured in accordance with BS EN 10025 or approved equivalent standards.
- Welding works are carried out in compliance with BS EN 1011-2 to ensure structural quality.
- Finished products are hot-dip galvanized to ISO 1461 for corrosion protection and long service life.



LIGHTING COLUMN



Headframe 1

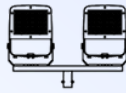

Headframe 2

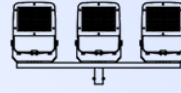

Headframe 3

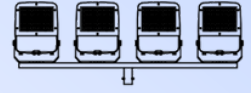

Headframe 4
(Straight)

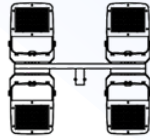

Headframe 4
(Up & Down)



Headframe 4
(Round)

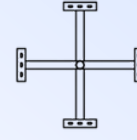

Headframe 4
(Cross)

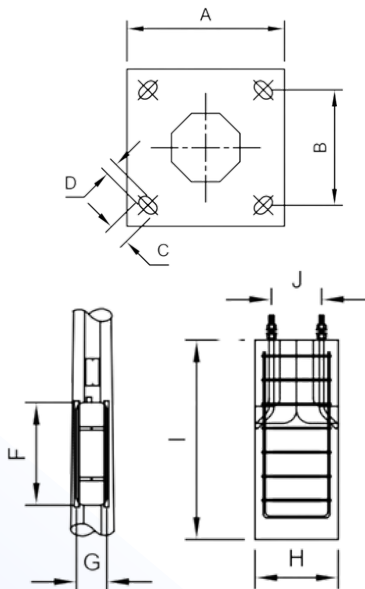

Flange Mounted:

Pole (M)	Section Height			Base Flange Plate			
	Bottom	Int	Top	Width (A)	C-C (B)	Hole (C x D)	Thickness
4	4000	-	-	250	195	35 x 20	9
6	6000	-	-	300	220	40 x 24	12
8	6450	-	1800	300	220	40 x 24	12
9	2000	-	7200	300	220	40 x 24	15
10	3000	-	7200	350	260	50 x 28	16
12	5000	-	7200	400	300	50 x 28	18

Pole (M)	Service Door		J-Bolt		Concrete Footing		
	Height (E)	Size (F x G)	Diameter	Length	Width (H)	Height (I)	C-C (J)
4	305	305 x 90	16	280	300	600	195
6	305	450 x 100	20	450	350	900	220
8	305	450 x 110	20	450	400	1000	220
9	610	450 x 110	20	450	400	1000	220
10	610	450 x 110	24	570	450	1100	260
12	610	450 x 120	24	570	500	1200	300

Planted Type:

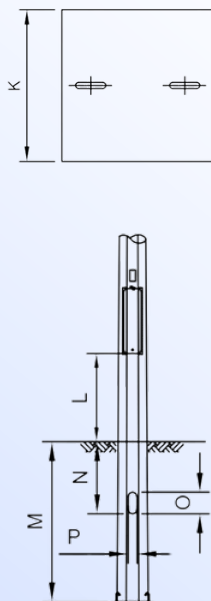

Pole (M)	Section Height			Anti-Sink Plate	
	Bottom	Int	Top	Width (K)	Thickness
4	5000	-	-	250	4
6	7200	-	-	250	4
8	2485	-	7200	300	4
9	3400	-	7200	300	4
10	4500	-	7200	300	4
12	6700	-	7200	300	4

Pole (M)	Service Door		Planting Depth		
	Height (L)	Size (F x G)	Depth (M)	Cable Depth (N)	Cable Entry (O x P)
4	305	305 x 90	1000	500	150 x 50
6	305	450 x 100	1200	500	150 x 60
8	305	450 x 110	1300	500	150 x 60
9	610	450 x 110	1400	500	150 x 60
10	610	450 x 110	1500	500	150 x 60
12	610	450 x 120	1700	500	150 x 60

MID-HINGED POLE



Our mid-hinged poles are designed for easy installation and maintenance, allowing the pole to be safely lowered without heavy lifting equipment. Built for strength and reliability, they are ideal for locations requiring frequent servicing while ensuring safety, efficiency, and reduced operational downtime.

Technical Specification:

- Lighting poles are designed to comply with major international standards, including AASHTO, AS/NZS, BS EN, MS, and SANS, ensuring safety and global acceptance.
- Structural design and analysis are performed using certified pole design software to verify strength and stability.
- All steel materials are manufactured in accordance with BS EN 10025 or approved equivalent standards.
- Welding works are carried out in compliance with BS EN 1011-2 to ensure structural quality.
- Finished products are hot-dip galvanized to ISO 1461 for corrosion protection and long service life.



LIGHTING COLUMN



Double Short Arm



Single Short Arm



Headframe 1

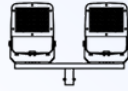

Headframe 2

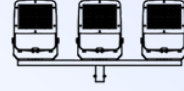

Headframe 3

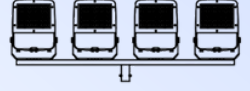

Headframe 4 (Straight)

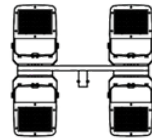

Headframe 4 (Up & Down)

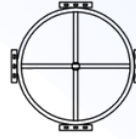

Headframe 4 (Round)

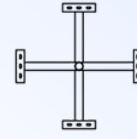

Headframe 4 (Cross)

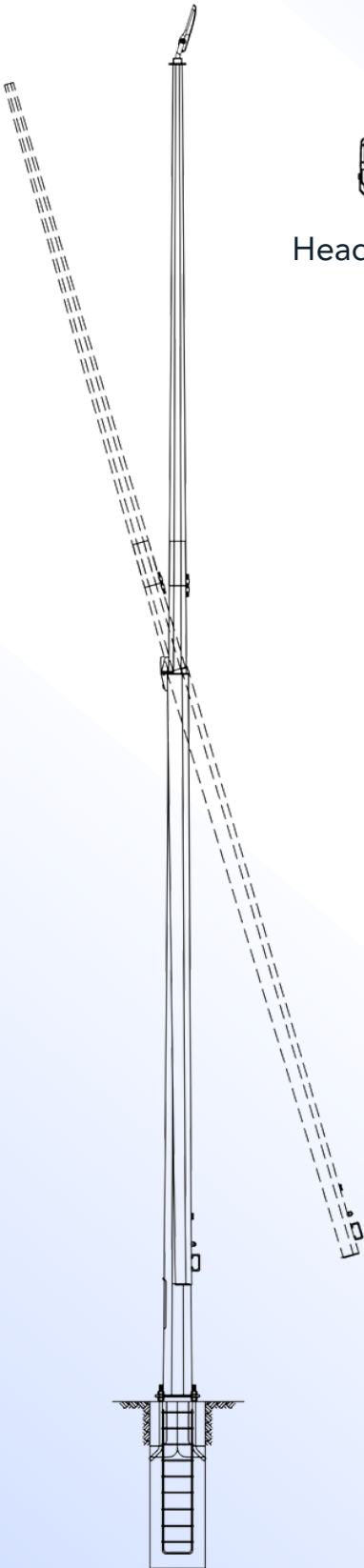
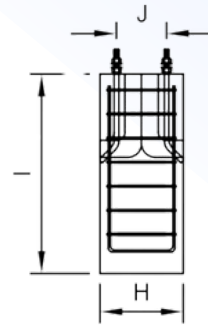
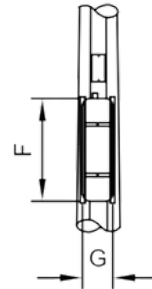
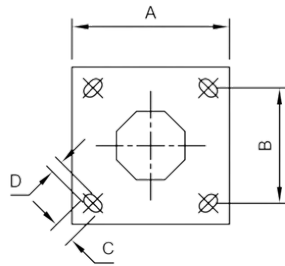

Flange Mounted:

Pole (M)	Top Load (KG)			Base Flange Plate			
	Light Duty	Medium Duty	Heavy Duty	Width (A)	C-C (B)	Hole (C x D)	Thickness
4	10	-	15	250	195	35 x 20	9
6	10	-	20	300	220	40 x 24	12
8	15	20	30	300	220	40 x 24	12
9	15	25	40	300	220	40 x 24	15
10	20	30	50	350	260	50 x 28	16
12	20	40	60	400	300	50 x 28	18
Pole (M)	Service Door		J-Bolt		Concrete Footing		
	Height (E)	Size (F x G)	Diameter	Length	Width (H)	Height (I)	C-C (J)
4	305	90	16	280	300	600	195
6	305	100	20	450	350	900	220
8	305	110	20	450	400	1000	220
9	610	120	20	450	400	1000	220
10	610	120	24	570	450	1100	260
12	610	120	24	570	500	1200	300

CLIMBING RUNG POLE



Our climbing rung poles are designed with integrated access rungs to provide safe and convenient vertical access for maintenance and installation works. Built for strength, stability, and worker safety, they are ideal for high-mast and floodlighting applications where reliable climbing access is essential.

Technical Specification:

- Lighting poles are designed to comply with major international standards, including AASHTO, AS/NZS, BS EN, MS, and SANS, ensuring safety and global acceptance.
- Structural design and analysis are performed using certified pole design software to verify strength and stability.
- All steel materials are manufactured in accordance with BS EN 10025 or approved equivalent standards.
- Welding works are carried out in compliance with BS EN 1011-2 to ensure structural quality.
- Finished products are hot-dip galvanized to ISO 1461 for corrosion protection and long service life.





Double Short Arm



Single Short Arm



Headframe 1

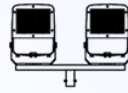

Headframe 2

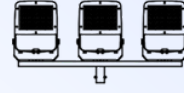

Headframe 3

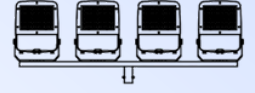

Headframe 4 (Straight)

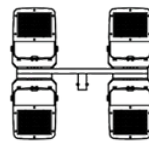

Headframe 4 (Up & Down)

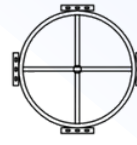

Headframe 4 (Round)

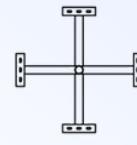

Headframe 4 (Cross)

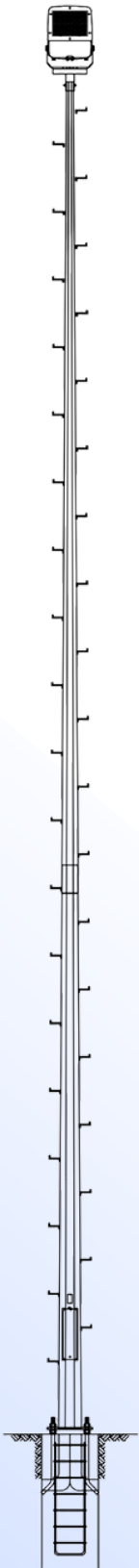
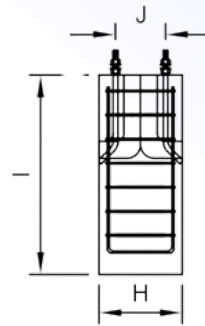
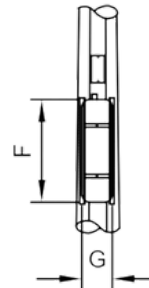
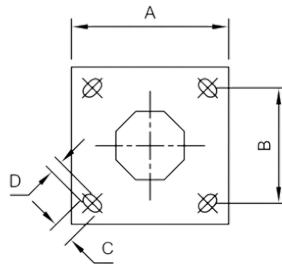

Flange Mounted:

Pole (M)	Top & Bottom AF			Base Flange Plate			
	Light Duty	Medium Duty	Heavy Duty	Width (A)	C-C (B)	Hole (C x D)	Thickness
6	60 / 135	-	-	300	220	40 x 24	12
8	60 / 158	81 / 173	-	300	220	40 x 24	12
9	60 / 161	81 / 181	94 / 215	300	220	40 x 24	15
10	60 / 173	81 / 197	94 / 230	350	260	50 x 28	16
12	60 / 197	81 / 218	94 / 260	400	300	50 x 28	18
Pole (M)	Service Door		J-Bolt		Concrete Footing		
	Height (E)	Size (F x G)	Diameter	Length	Width (H)	Height (I)	C-C (J)
6	305	450 x 100	20	450	350	900	220
8	305	450 x 110	20	450	400	1000	220
9	610	450 x 110	20	450	400	1000/1300	220
10	610	450 x 110	24	570	450	1100/1300	260
12	610	450 x 120	24	570	500	1200/1500	300



MULTI-SEGMENT TUBULAR POLE

Our multi-segment tubular poles are engineered for structural efficiency, durability, and ease of installation. Fabricated from precision-aligned tubular sections, they provide robust support for lighting, telecom, and infrastructure applications. Designed for long-term performance and optimized load distribution, they offer a reliable and cost-effective solution for urban and industrial environments.

Technical Specification:

- Lighting poles are designed to comply with major international standards, including AASHTO, AS/NZS, BS EN, MS, and SANS, ensuring safety and global acceptance.
- Structural design and analysis are performed using certified pole design software to verify strength and stability.
- All steel materials are manufactured in accordance with BS EN 10025 or approved equivalent standards.
- Welding works are carried out in compliance with BS EN 1011-2 to ensure structural quality.
- Finished products are hot-dip galvanized to ISO 1461 for corrosion protection and long service life.

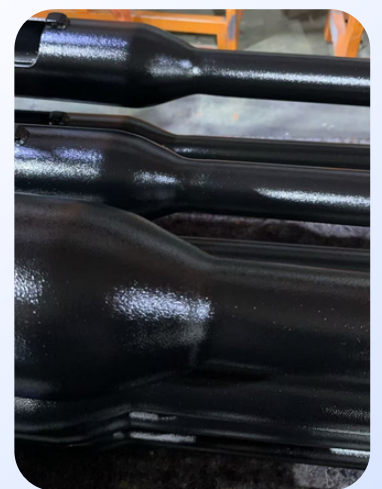
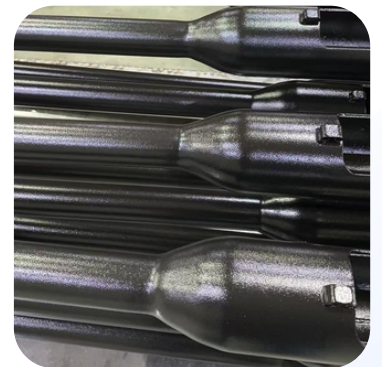

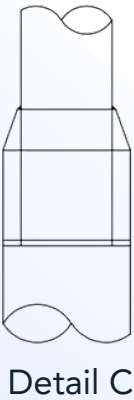
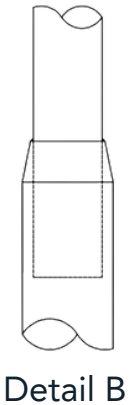
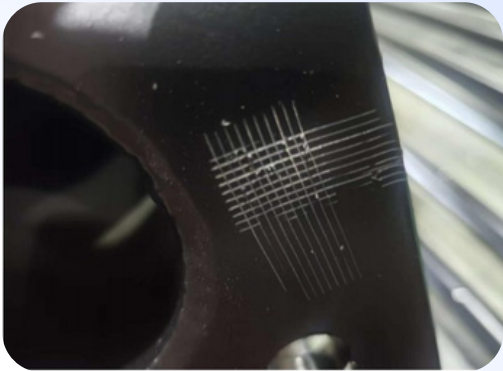
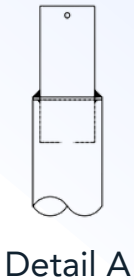
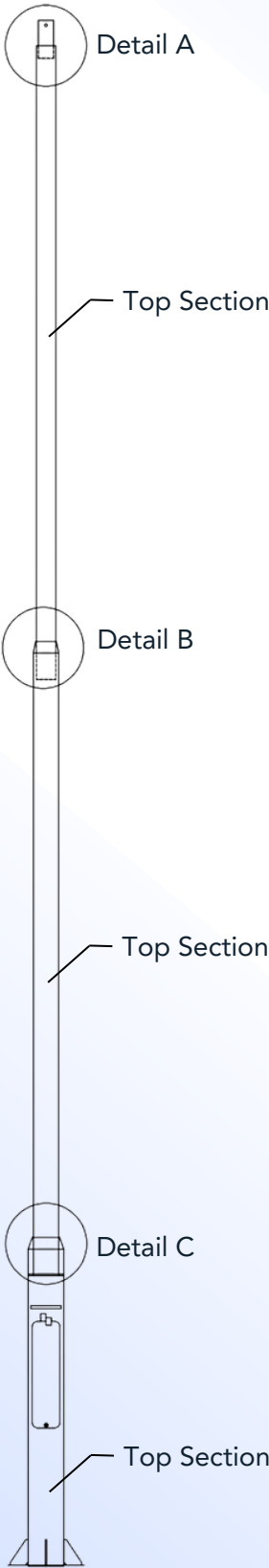

HIGH MAST



Our high masts are designed for powerful, wide-area illumination in large outdoor spaces such as ports, stadiums, and highways. Engineered for strength and stability, they provide reliable performance, ease of maintenance, and optimal visibility across extensive areas.

Technical Specification:

- Lighting poles are designed to comply with major international standards, including AASHTO, AS/NZS, BS EN, MS, and SANS, ensuring safety and global acceptance.
- Structural design and analysis are performed using certified pole design software to verify strength and stability.
- All steel materials are manufactured in accordance with BS EN 10025 or approved equivalent standards.
- Welding works are carried out in compliance with BS EN 1011-2 to ensure structural quality.
- Finished products are hot-dip galvanized to ISO 1461 for corrosion protection and long service life.





Supports Up to 45m Height

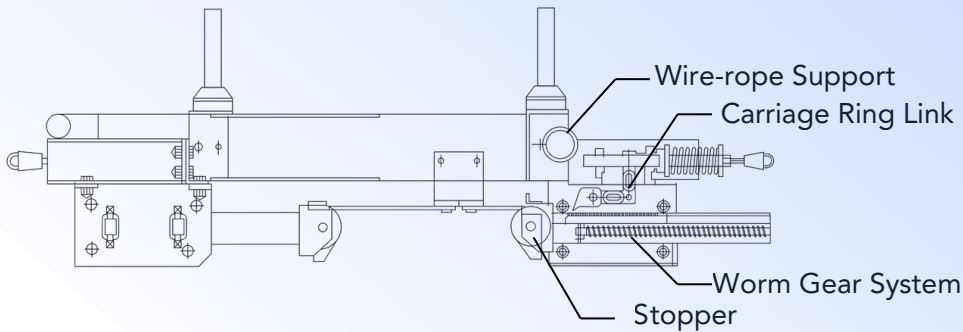

Anti-Fall Safety Security System

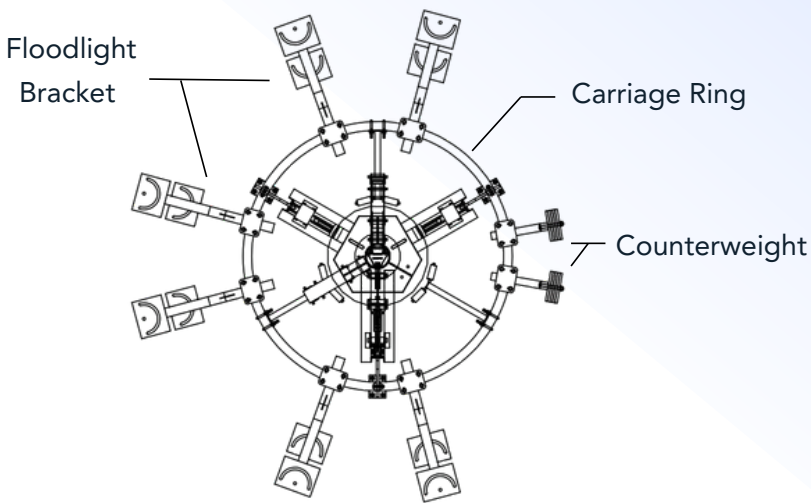

Custom Floodlight Configuration

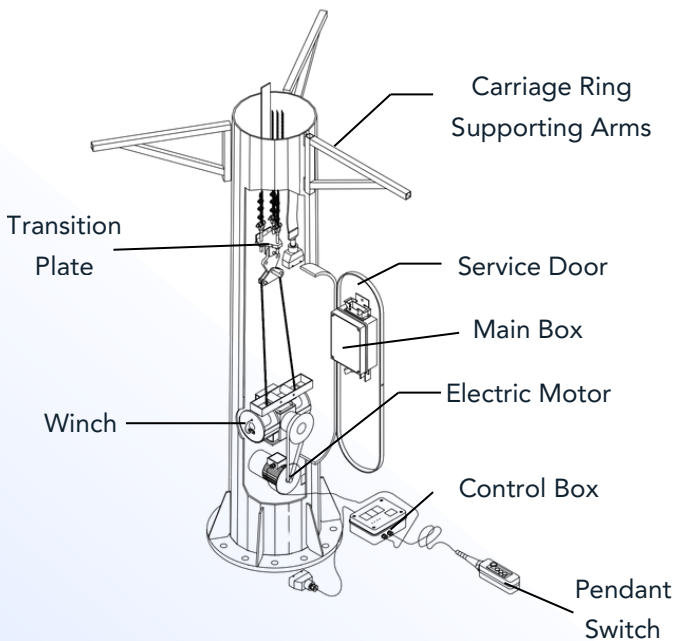

Hoist, Motor and Electrical System

STADIUM MAST



Our stadium masts are engineered to support high-intensity lighting for sports arenas and large venues. Built for maximum height, stability, and durability, they deliver uniform illumination, enhance safety, and ensure an exceptional viewing experience for spectators.

Technical Specification:

- Lighting poles are designed to comply with major international standards, including AASHTO, AS/NZS, BS EN, MS, and SANS, ensuring safety and global acceptance.
- Structural design and analysis are performed using certified pole design software to verify strength and stability.
- All steel materials are manufactured in accordance with BS EN 10025 or approved equivalent standards.
- Welding works are carried out in compliance with BS EN 1011-2 to ensure structural quality.
- Finished products are hot-dip galvanized to ISO 1461 for corrosion protection and long service life.



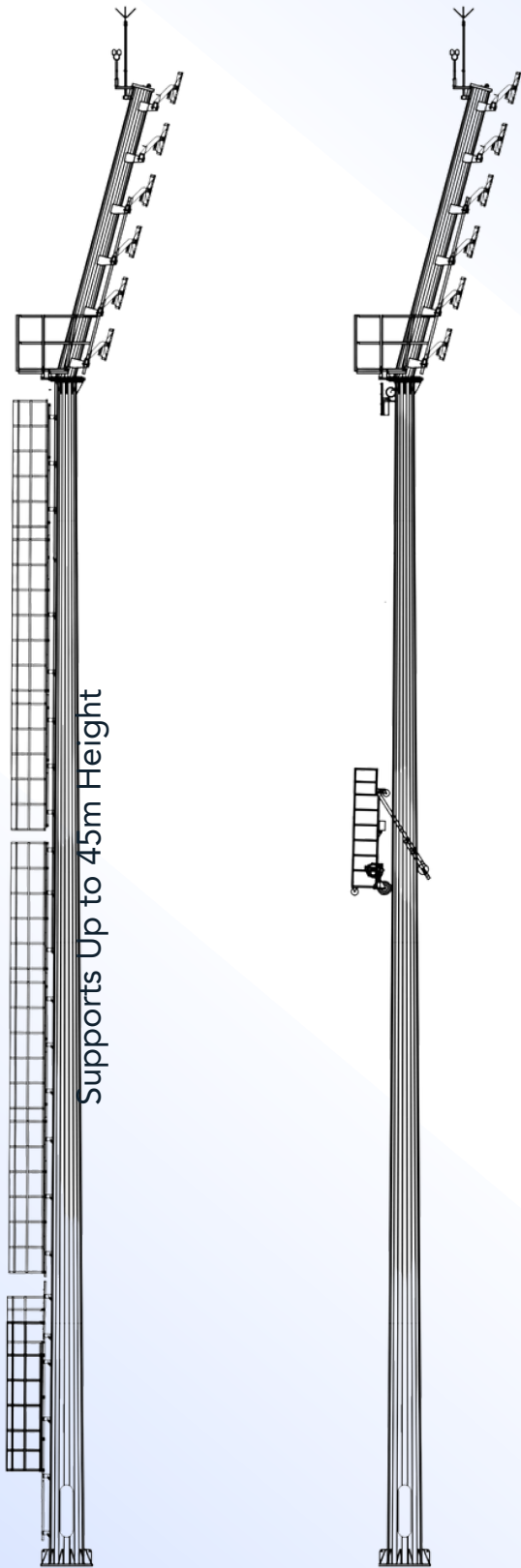

Supports Up to 45m Height

Option A:

Climbing Ladder

Option B:

Maintenance Cage

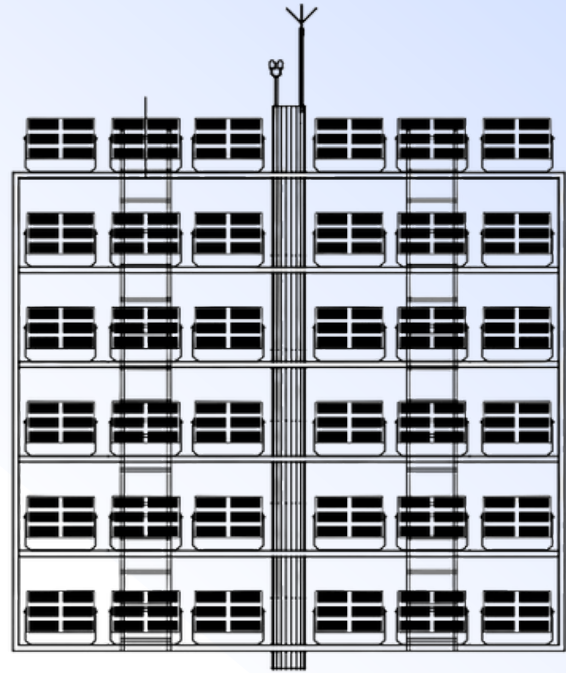

Custom Floodlight Configuration

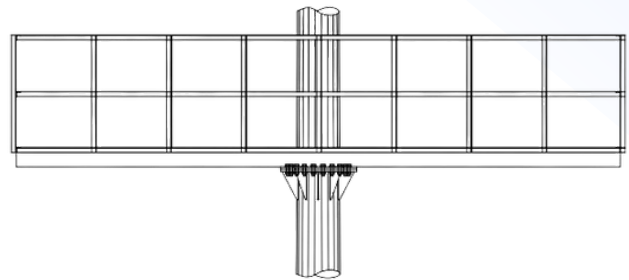

Equipped with Working Platform

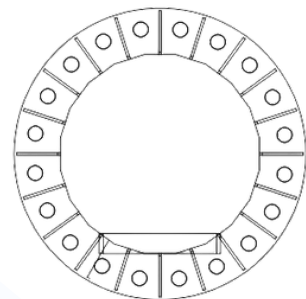

Supplied with I-Bolt and Template
for Accurate Footing Cast





SPECIAL APPLICATION COLUMN

CCTV POLE



Our CCTV poles provide secure, durable, and unobtrusive support for surveillance cameras. Designed for easy installation and reliable performance, they ensure optimal camera positioning for effective monitoring and safety in urban, commercial, and industrial environments.

Technical Specification:

- Lighting poles are designed to comply with major international standards, including AASHTO, AS/NZS, BS EN, MS, and SANS, ensuring safety and global acceptance.
- Structural design and analysis are performed using certified pole design software to verify strength and stability.
- All steel materials are manufactured in accordance with BS EN 10025 or approved equivalent standards.
- Welding works are carried out in compliance with BS EN 1011-2 to ensure structural quality.
- Finished products are hot-dip galvanized to ISO 1461 for corrosion protection and long service life.



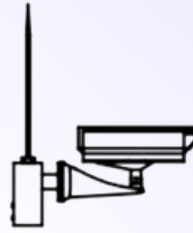
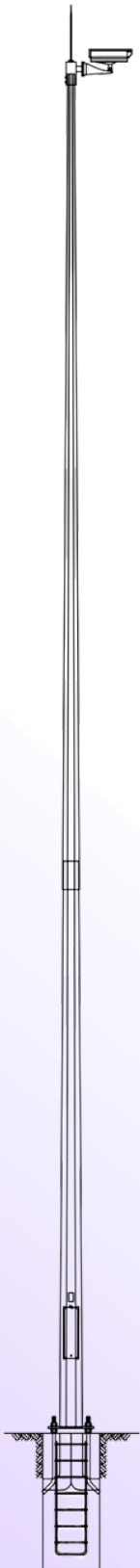

Single CCTV

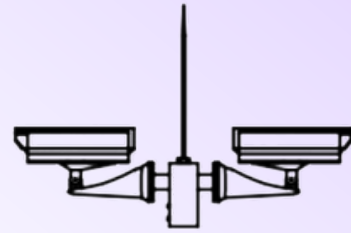

Double CCTV

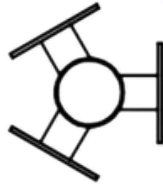

Triple CCTV

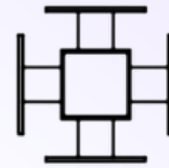

360° CCTV

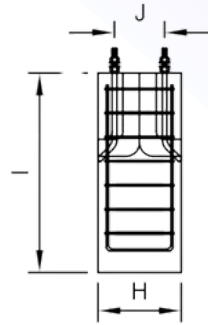
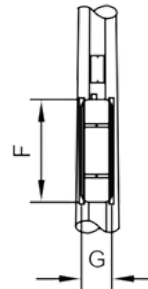
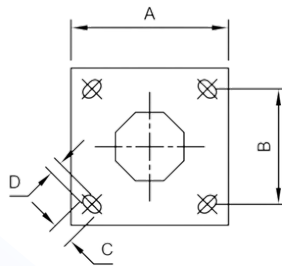

Flange Mounted:

Pole (M)	Top & Bottom AF			Base Flange Plate			
	Light Duty	Medium Duty	Heavy Duty	Width (A)	C-C (B)	Hole (C x D)	Thickness
6	60 / 135	-	-	300	220	40 x 24	12
8	60 / 158	81 / 173	-	300	220	40 x 24	12
9	60 / 161	81 / 181	94 / 215	300	220	40 x 24	15
10	60 / 173	81 / 197	94 / 230	350	260	50 x 28	16
12	60 / 197	81 / 218	94 / 260	400	300	50 x 28	18
Pole (M)	Service Door		J-Bolt		Concrete Footing		
	Height (E)	Size (F x G)	Diameter	Length	Width (H)	Height (I)	C-C (J)
6	305	450 x 100	20	450	350	900	220
8	305	450 x 110	20	450	400	1000	220
9	610	450 x 110	20	450	400	1000/1300	220
10	610	450 x 110	24	570	450	1100/1300	260
12	610	450 x 120	24	570	500	1200/1500	300

TRAFFIC LIGHT POLE



Our traffic light poles are engineered for durability and reliability, providing stable support for traffic signals, signage, and auxiliary equipment. Designed for safety and long-term performance, they are ideal for urban intersections and smart traffic management systems.

Technical Specification:

- Lighting poles are designed to comply with major international standards, including AASHTO, AS/NZS, BS EN, MS, and SANS, ensuring safety and global acceptance.
- Structural design and analysis are performed using certified pole design software to verify strength and stability.
- All steel materials are manufactured in accordance with BS EN 10025 or approved equivalent standards.
- Welding works are carried out in compliance with BS EN 1011-2 to ensure structural quality.
- Finished products are hot-dip galvanized to ISO 1461 for corrosion protection and long service life.





JUMA Traffic Light Pole



Double Short Arm



Single Short Arm

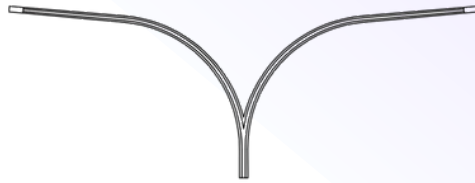

Double Curve Arm

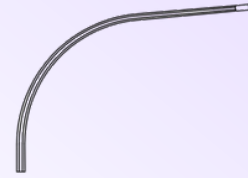

Single Curve Arm

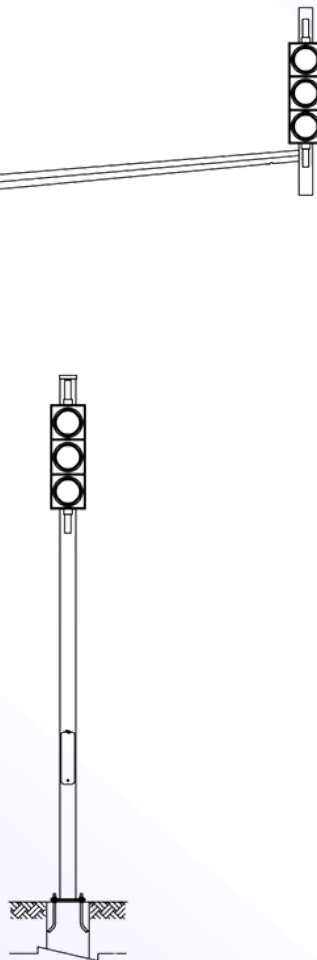

Circular Vertical Traffic Light Pole

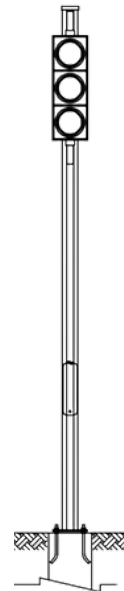

Octagonal Vertical Traffic Light Pole

TELCO MONOPOLE



Our telecommunication monopoles are designed to provide a strong and stable platform for antennas and communication equipment. Engineered for durability, easy installation, and minimal maintenance, they support reliable connectivity for mobile networks, broadband, and smart-city infrastructure.

Technical Specification:

- Lighting poles are designed to comply with major international standards, including TIA-222-H, AASHTO, AS/NZS, BS EN, MS, and SANS, ensuring safety and global acceptance.
- Structural design and analysis are performed using certified pole design software to verify strength and stability.
- All steel materials are manufactured in accordance with BS EN 10025 or approved equivalent standards.
- Welding works are carried out in compliance with BS EN 1011-2 to ensure structural quality.
- Finished products are hot-dip galvanized to ISO 1461 for corrosion protection and long service life.



Mounting Options:

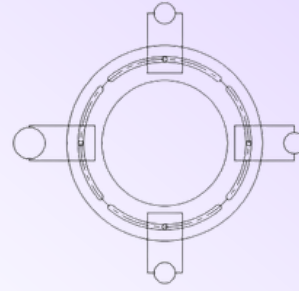
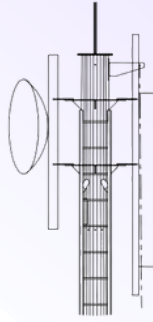

Option A: Plate-mounted system enabling quick and efficient installation.

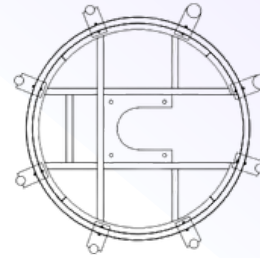
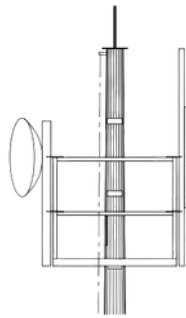

Option B: Platform-mounted system designed for secure installation and easy equipment access.

Camouflage Options:



Available with fibreglass camouflage or camouflage tree options for discreet infrastructure deployment.



MULTI-FUNCTION SMART POLE

Our multi-purpose columns are designed to support a wide range of applications, combining strength, flexibility, and clean aesthetics in a single structure. Engineered to accommodate lighting, signage, cameras, and smart-city equipment, they provide a versatile and future-ready solution for modern infrastructure.

Technical Specification:

- Lighting poles are designed to comply with major international standards, including AASHTO, AS/NZS, BS EN, MS, and SANS, ensuring safety and global acceptance.
- Structural design and analysis are performed using certified pole design software to verify strength and stability.
- All steel materials are manufactured in accordance with BS EN 10025 or approved equivalent standards.
- Welding works are carried out in compliance with BS EN 1011-2 to ensure structural quality.
- Finished products are hot-dip galvanized to ISO 1461 for corrosion protection and long service life.



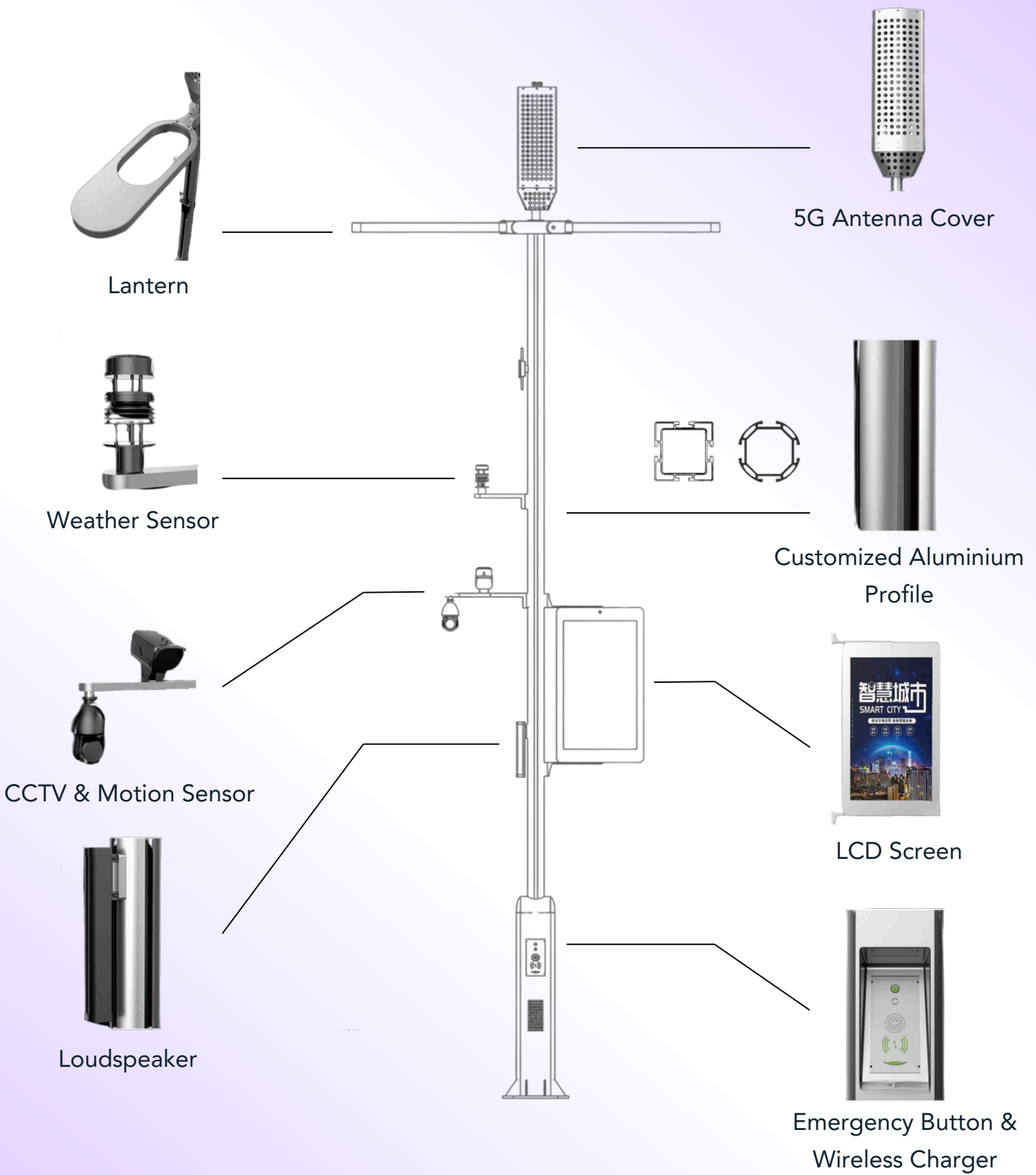





AESTHETIC COLUMN

DECORATIVE POLE



Our decorative poles combine structural strength with refined aesthetics to enhance the visual character of urban and public spaces. Designed to complement architectural themes while delivering reliable performance, they are ideal for streetscapes, parks, and landmark areas.

Technical Specification:

- Lighting poles are designed to comply with major international standards, including AASHTO, AS/NZS, BS EN, MS, and SANS, ensuring safety and global acceptance.
- Structural design and analysis are performed using certified pole design software to verify strength and stability.
- All steel materials are manufactured in accordance with BS EN 10025 or approved equivalent standards.
- Welding works are carried out in compliance with BS EN 1011-2 to ensure structural quality.
- Finished products are hot-dip galvanized to ISO 1461 for corrosion protection and long service life.

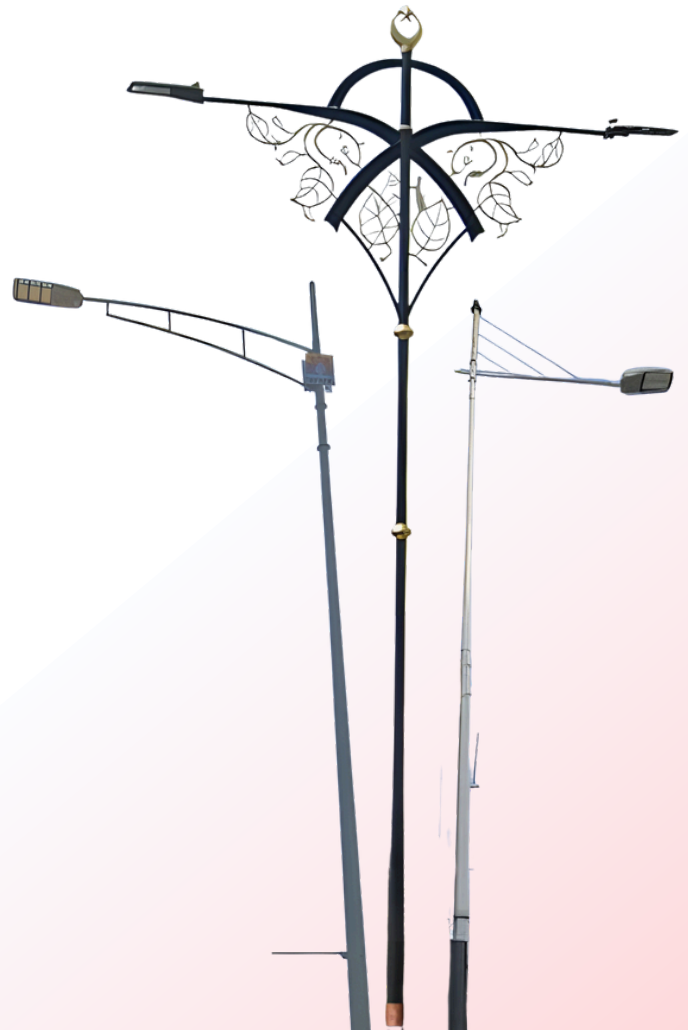



Location: Selayang



Location: Kajang



Location: Kajang



Location: Seberang
Perai



Location: Kuala
Selangor



Location: Pasir Gudang



Location: Johor Bahru



Location: Iskandar
Puteri



Location: Shah Alam

COMPOUND LIGHTING



Our compound lighting poles are engineered to support multiple lighting fixtures and equipment on a single structure. Combining strength, versatility, and space efficiency, they are ideal for roads, intersections, and large public areas requiring comprehensive illumination and integrated functionality.

Technical Specification:

- Lighting poles are designed to comply with major international standards, including AASHTO, AS/NZS, BS EN, MS, and SANS, ensuring safety and global acceptance.
- Structural design and analysis are performed using certified pole design software to verify strength and stability.
- All steel materials are manufactured in accordance with BS EN 10025 or approved equivalent standards.
- Welding works are carried out in compliance with BS EN 1011-2 to ensure structural quality.
- Finished products are hot-dip galvanized to ISO 1461 for corrosion protection and long service life.



LANDSCAPE LIGHTING

Our landscape lighting solutions provide low-level, glare-controlled illumination to enhance safety and aesthetics in pedestrian areas. Designed for durability and visual appeal, they are ideal for pathways, landscapes, parks, and public spaces.

Technical Specification:

- Lighting poles are designed to comply with major international standards, including AASHTO, AS/NZS, BS EN, MS, and SANS, ensuring safety and global acceptance.
- Structural design and analysis are performed using certified pole design software to verify strength and stability.
- All steel materials are manufactured in accordance with BS EN 10025 or approved equivalent standards.
- Welding works are carried out in compliance with BS EN 1011-2 to ensure structural quality.
- Finished products are hot-dip galvanized to ISO 1461 for corrosion protection and long service life.



DIRECTIONAL MAP:

Morelux Pole Technology (Malaysia) Sdn. Bhd.

GPS Coordinate: 3°01'53.4"N 101°33'23.1"E

From
Klang / Kota
Kemuning

From
Subang Jaya /
Petaling Jaya

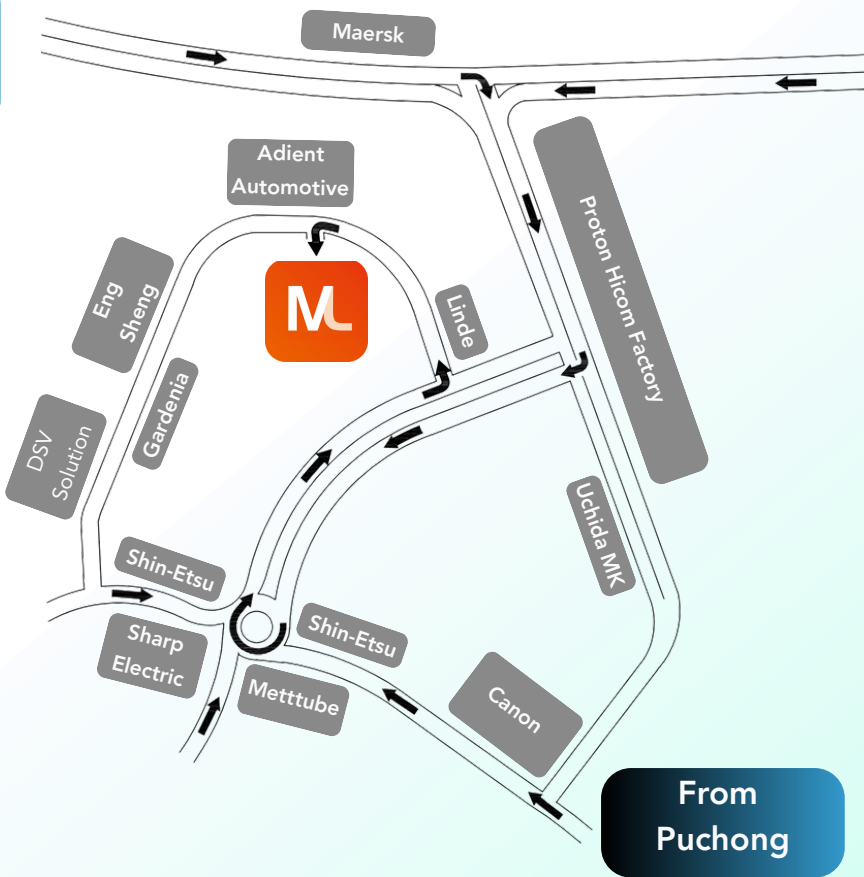

From
Puchong



Morelux Pole Technology (Malaysia) Sdn. Bhd.

 Address: : Lot 509, Persiaran Sabak Bernam,
Hicom Industrial Estate,
40400 Shah Alam, Selangor.

 Email : info@moreluxpole.com.my

 Website : www.moreluxpole.com.my

 Phone : +60 12 354 4816 (Albert Tan)

